



SC-101

User's Manual

RS232 to RS422/485 Converter



1. Introduction

The SC-101 allows RS232 line signal bi-directionally convert to RS422 or RS485 standard. Featuring data format DIP switching and baud rate auto switching (from 110bps to 115.2Kbps) users just need to plug the unit and go without software or hardware complicated setting. The RS485 control is completely transparent to the user and software written for Half-Duplex RS232 works without any modification. The internal surge-protection.

1-1. Features

- Low Cost
- Ease Install
- Baud rate up to 115.2 Kbps.
- 15KV ESD Protection
- Power support from RS232 or DC Jack
- Select half duplex or full duplex
- Low power

1-2. Specification.

- Power input voltage: DC +5V OR USB POWER
- Output:RS422/RS485 protocol.
- Host connection: Standard D-Sub 9 pin male connector
- Electromagnetic Compatibility: CE,FCC
- Communication speed: form 110bps to 115.2Kbps auto-switching.
- RS422/485 line protection: Against surge.
- Distance: up to 4000ft (1250M).
- Connection type: Screw terminal for maximum AWG 12 wire.
- Signal LED: TX, RX.
- Power supply: standard DC adapter.
- Power consumption: <0.2W
- Operating environment: 0 to 60°C .
- Storage temperature: 0 to 70°C .
- Dimension: 55mm X 42mm X 25mm.
- Weight: 39g.
- Humidity: 5-95% non-condensing.

2. SC-101 panel layout

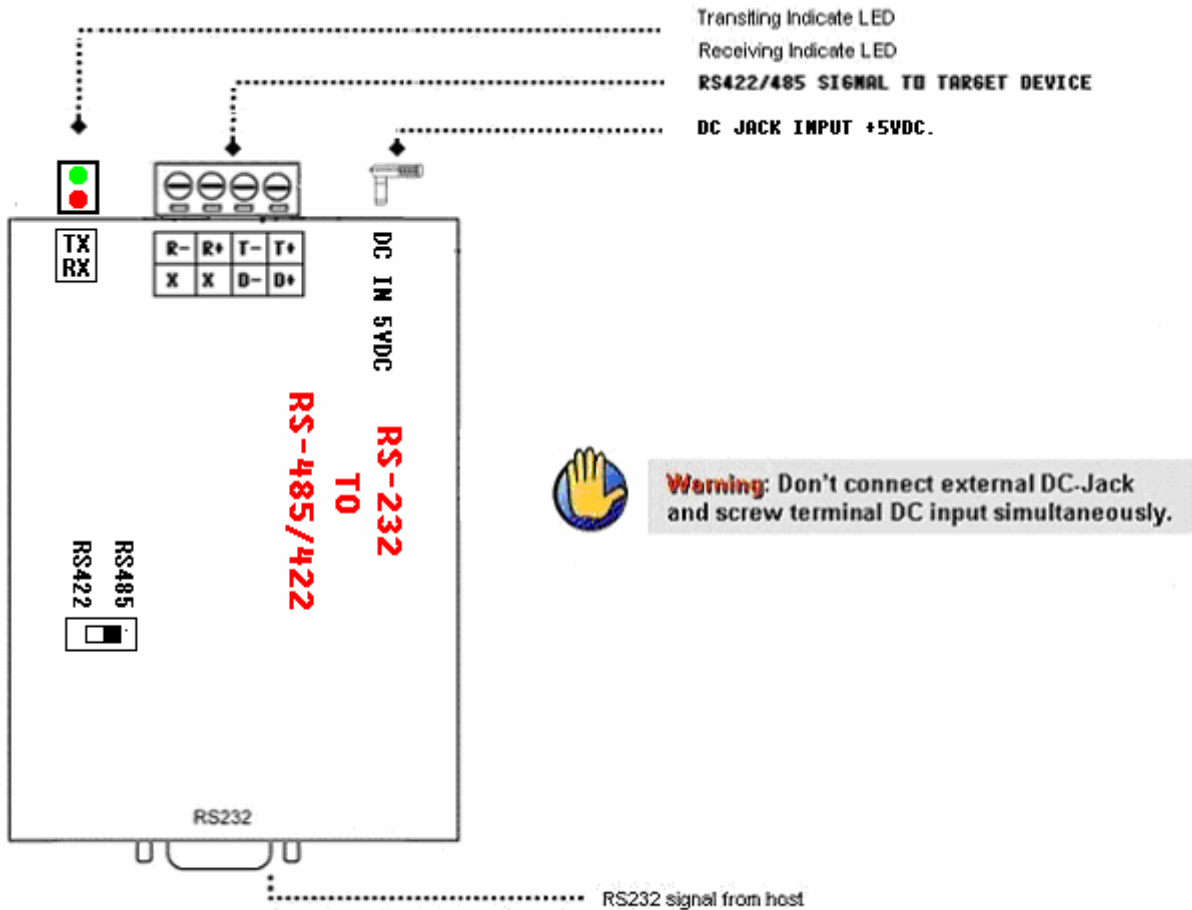

3. SC-101 Hardware structure

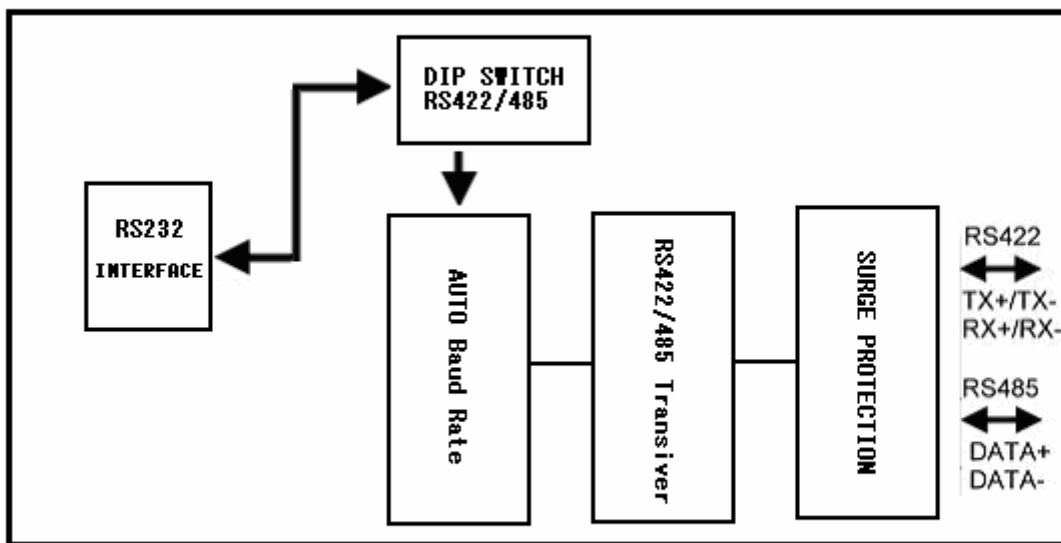

4. Install SC-101

4-1. Connect power source or use standard RS232 (TXD,RXD,DTR,DSR,CTS,RTS,GND)

Warning: only power source

Do not use external DC-Jack and screw terminal DC input simultaneously.

4-2. Connect SC-101 with Host PC.

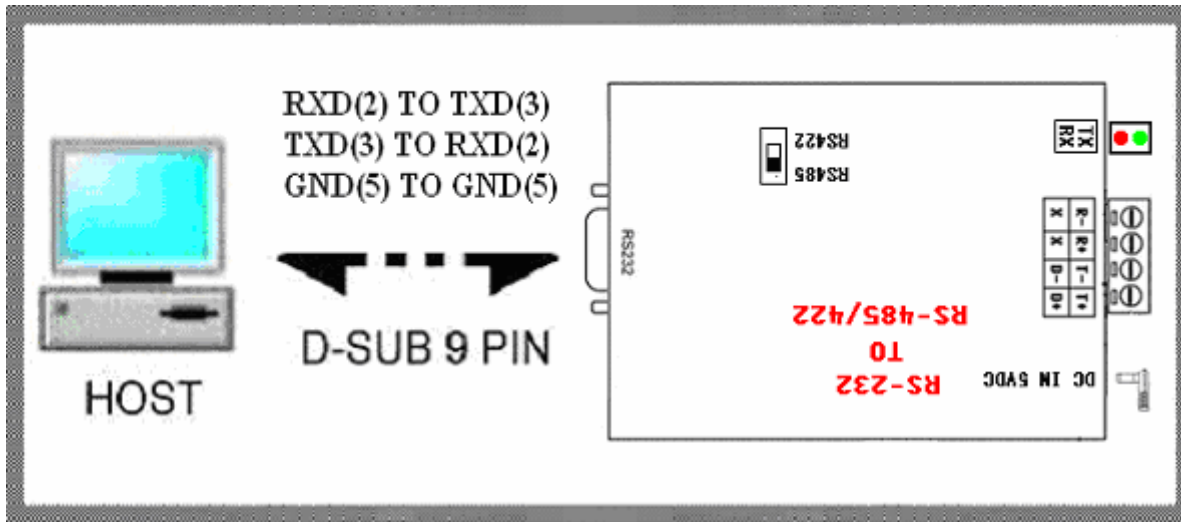

4-3. Connect SC-485 with RS4222 or RS422/485 serial device.

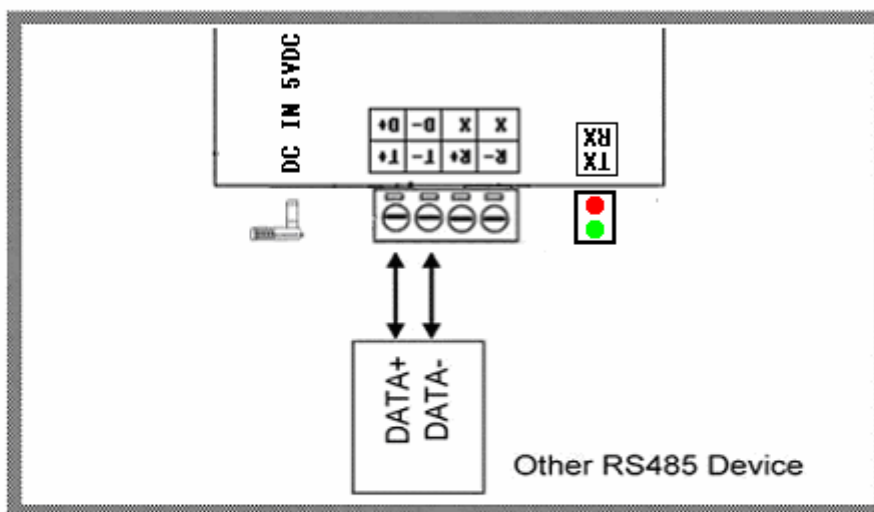

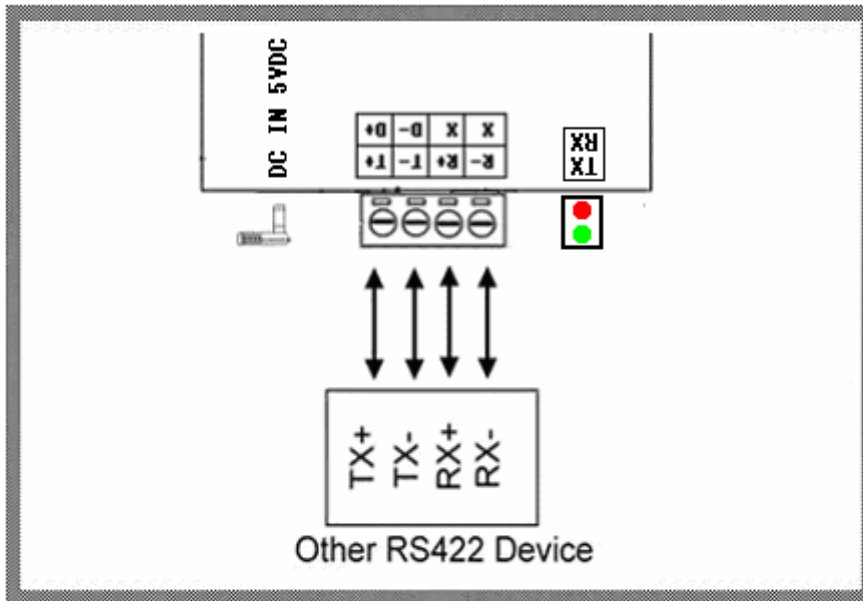

5. Loop back test

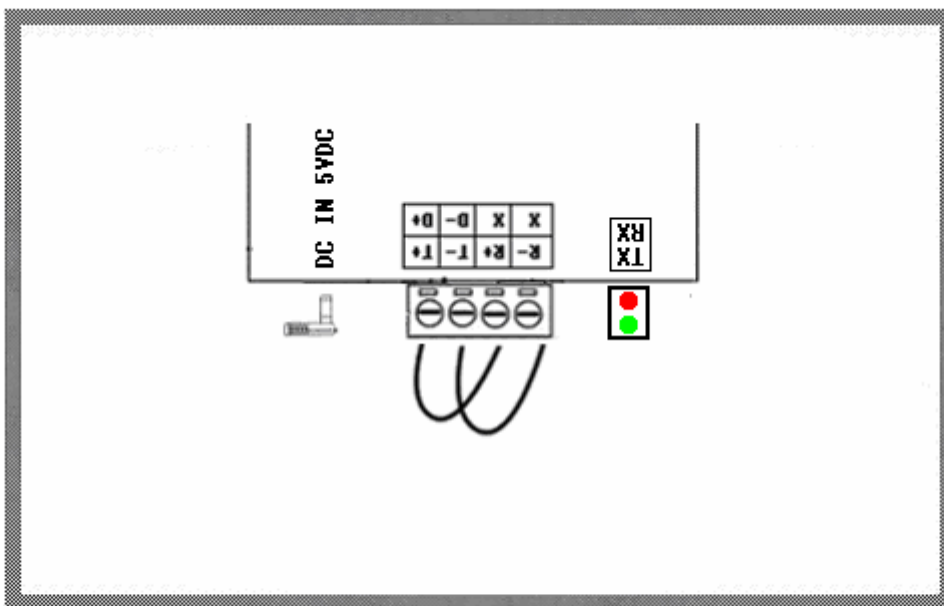

6. Terminal Resistor connection.

SC-101 does not have built-in terminal resistor, user may add external terminal resistor by following connection.

6-1. RS485

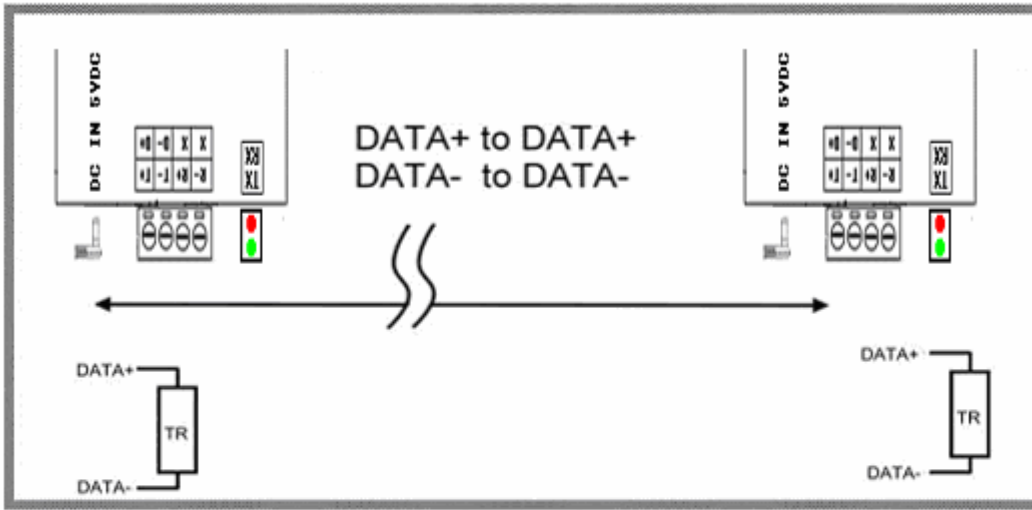

Terminal Resistor specification.

110 ohm: If distance between both end of RS485 devices in 1.2KM .

220 ohm: If distance between both end of RS485 devices in 600M .

330 ohm: If distance between both end of RS485 devices in 300M

6-2. RS422

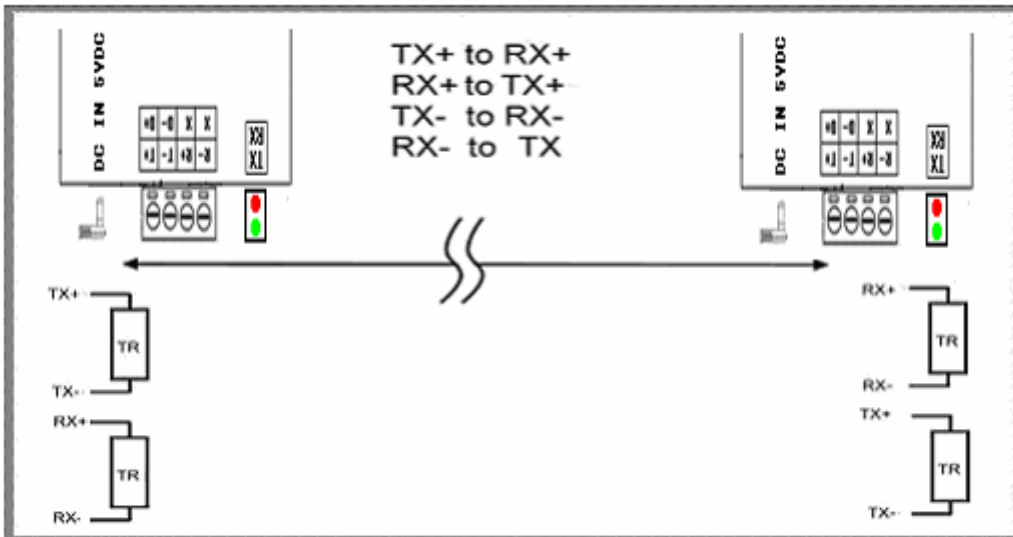

Terminal Resistor specification...

110 ohm: If distance between both ends of RS422 devices in 1.2KM.

220 ohm: If distance between both ends of RS422 devices in 600M.

330 ohm: If distance between both ends of RS422 devices in 300M

