

General Current Transformer

Current Transformer

J series

Specification

Model	Inner Dia.	Turns Ratio	Current Range	Winding Resistance (DCR)	Burden Resistance
JS31V	Ø7.0	1000/1	100mA-80A	55Ω ±10%	10Ω
JH3V	Ø7.0	2500/1	100mA-100A	135Ω ±10%	50Ω
JS41V	Ø9.0	1000/1	100mA-110A	77Ω ±10%	10Ω
JH4V	Ø9.0	2500/1	100mA-180A	199Ω ±10%	50Ω
JS51V	Ø13.1	1000/1	100mA-200A	40Ω ±10%	10Ω
JH5V	Ø13.1	2500/1	100mA-300A	110Ω ±10%	10Ω
JH54V	Ø13.1	4000/1	100mA-400A	290Ω ±10%	10Ω
JS31W	Ø7.0	1000/1	100mA-80A	55Ω ±10%	10Ω
JS41W	Ø9.0	1000/1	100mA-110A	77Ω ±10%	10Ω
JS51W	Ø13.0	1000/1	100mA-200A	40Ω ±10%	10Ω
CT1000	Ø24.7	1000/1	100mA-200A	44Ω ±10%	10Ω
CT2000	Ø24.7	2000/1	100mA-330A	87Ω ±10%	10Ω
CT3000	Ø30	3000/1	100mA-600A	155Ω ±10%	2Ω
JCTP-80	Ø5.8	800/1	100mA-80A	38Ω ±10%	10Ω
JCTH-80	Ø6.10	800/1	100mA-80A	38Ω ±10%	10Ω
JH100G	Ø12.2	1000/1	100mA-200A	40Ω ±10%	10Ω
JG10	Ø6.0	1000/1	100mA-60A	64Ω ±10%	10Ω

* Operating Frequency 50Hz, Dielectric withstand 2'nd-Earth AC 2.5KV/1min

Dimension

Model	Drawing No.	A	B	C	D	E	F	G	H	I	J
JS31V	3-1	23.40	24.80	10.40	7.00	3.00	15.00	19.00	9.10	2.0	-
JH3V	3-1	23.40	24.80	10.40	7.00	3.00	15.00	19.00	9.10	2.0	-
JS41V	3-1	25.00	27.00	16.50	9.00	3.00	15.10	19.10	15.10	2.0	-
JH4V	3-1	25.00	27.00	16.50	9.00	3.00	15.10	19.10	15.10	2.0	-
JS51V	3-1	37.50	39.00	14.00	13.10	3.00	25.20	32.60	12.60	3.7	-
JH5V	3-1	37.50	39.00	14.00	13.10	3.00	25.20	32.60	12.60	3.7	-
JH54V	3-1	37.50	39.00	14.00	13.10	3.00	25.20	32.60	12.60	3.7	-
JS31W	3-2	23.30	26.50	10.50	7.00	90	3.40	3.80	7.00	3.0	-
JS41W	3-2	24.40	28.10	16.60	9.00	90	3.50	4.00	7.40	3.0	-
JS51W	3-2	37.10	40.80	13.50	13.00	110	3.70	4.50	10.00	3.0	-
CT1000	3-2	51.5	57.5	16.8	24.7	254	8	10.5	14.8	3.0	-
CT2000	3-2	51.5	57.5	16.8	24.7	254	8	10.5	14.8	3.0	-
CT3000	3-2	61.00	64.00	20.00	30.00	254	3.75	6.00	13.20	3.0	-
JCTP-80	3-4	Please refer to the Drawing dimension.									
JCTH-80	3-5	Please refer to the Drawing dimension.									
JH100G	3-7	Please refer to the Drawing dimension.									
JG10	3-8	Please refer to the Drawing dimension.									

* Unit : mm

Drawing Current Transformer

3-1

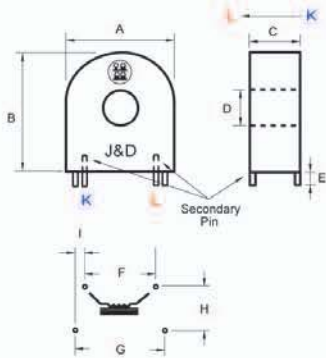

3-2

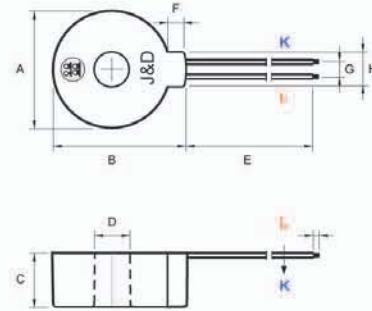

Unit : mm [inch]

3-3

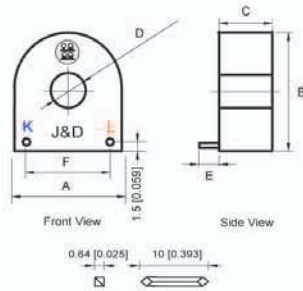

3-4

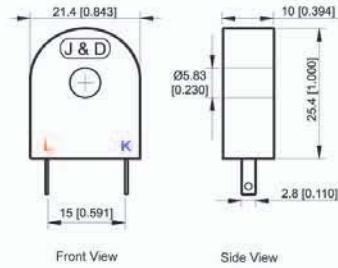

Unit : mm [inch]

3-5

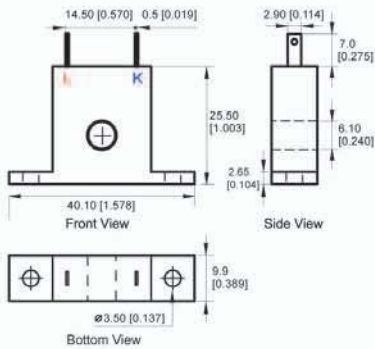

3-6

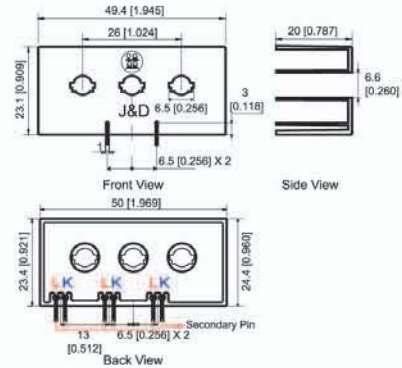

Unit : mm [inch]

3-7

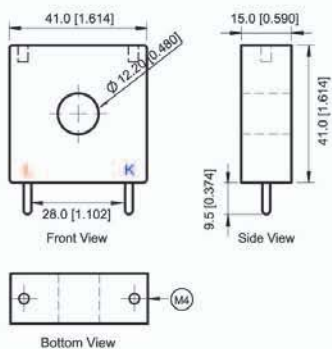

3-8

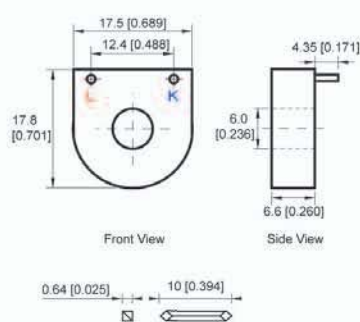

Unit : mm [inch]

Output Voltage Data

Current Transformer

Output Voltage Data

JL13

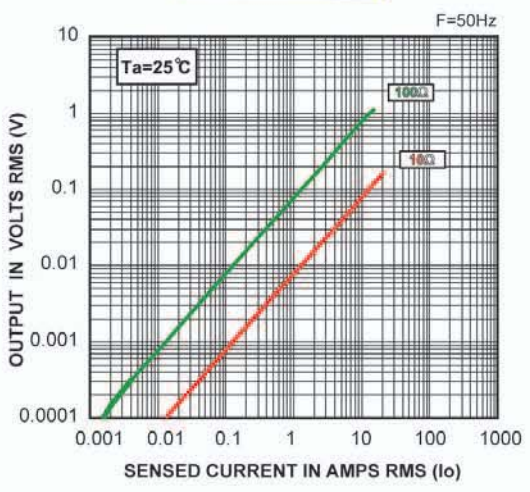

JL8

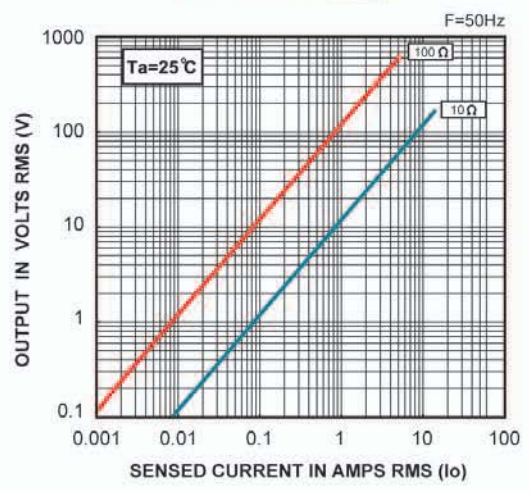

JCTP-80Z / JCTH-80Z

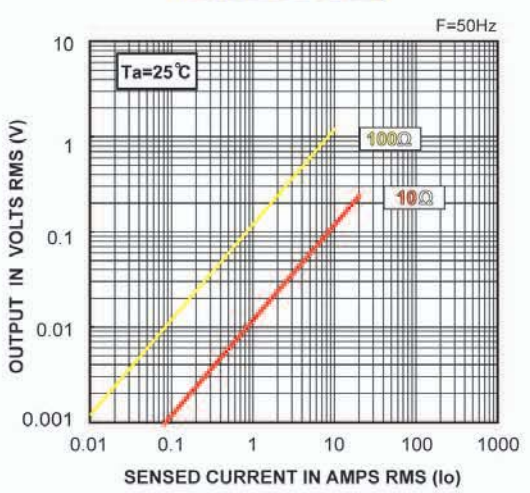

J3CT

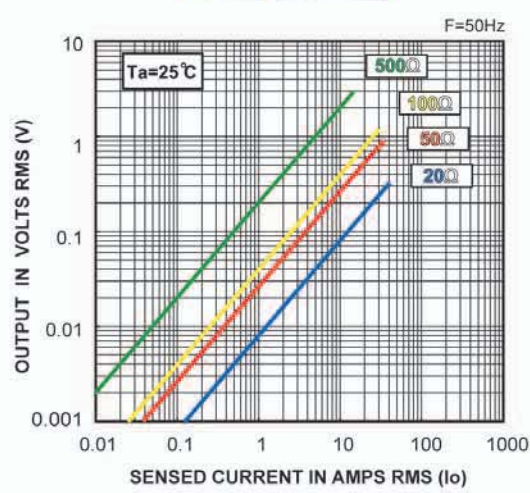

JCTS250Q

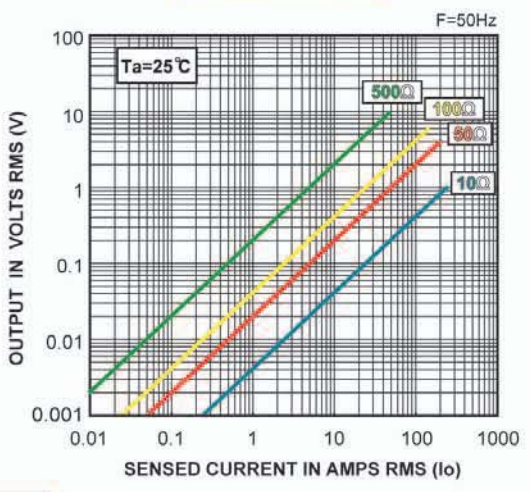

JS31V / JS31W

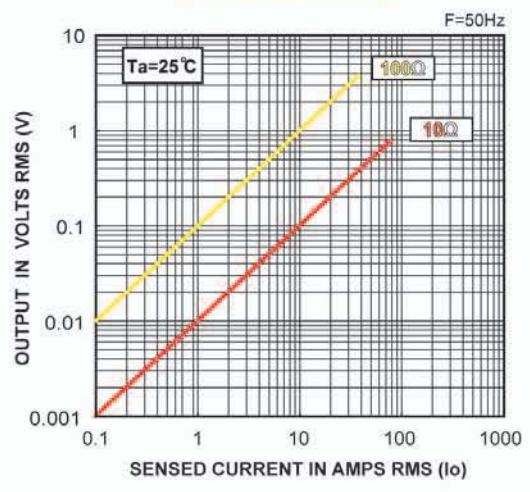

Output Voltage Data Current Transformer

JH3V

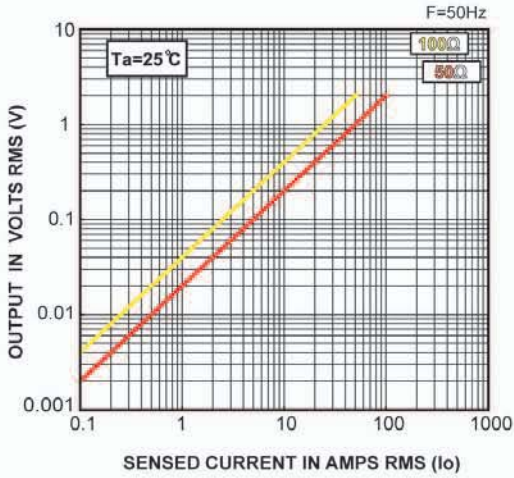

JS41V / JS41W

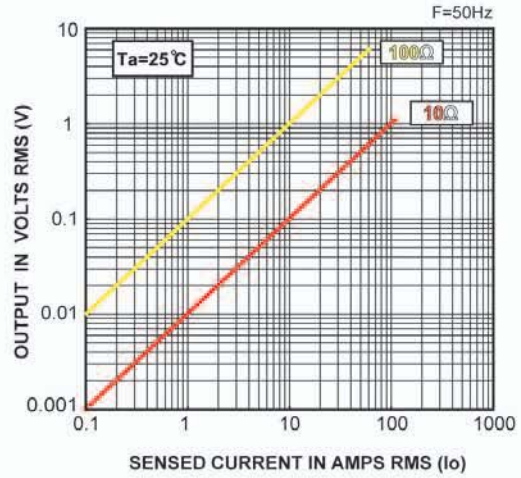

JH4V

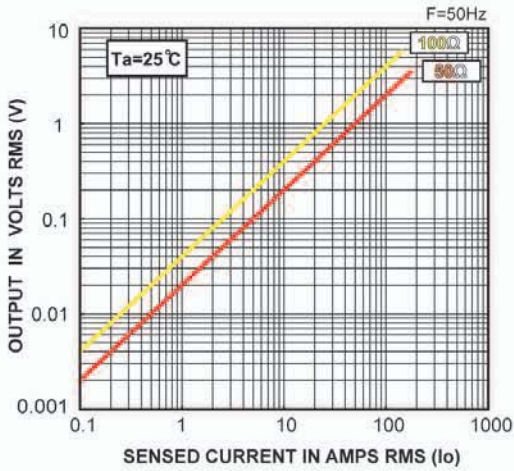

JS51V / JS51W

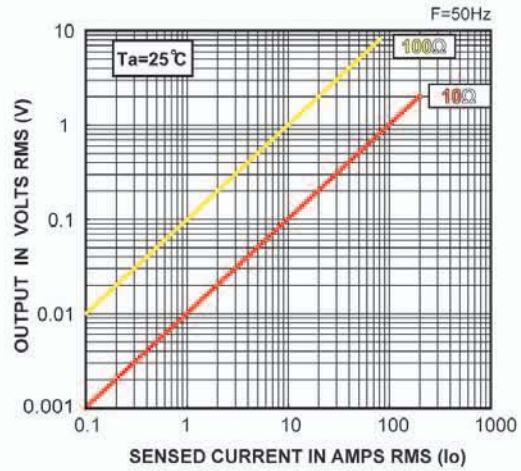

JH5V

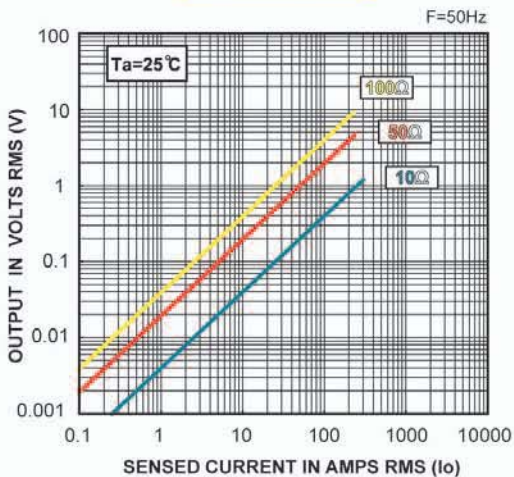

JH54V

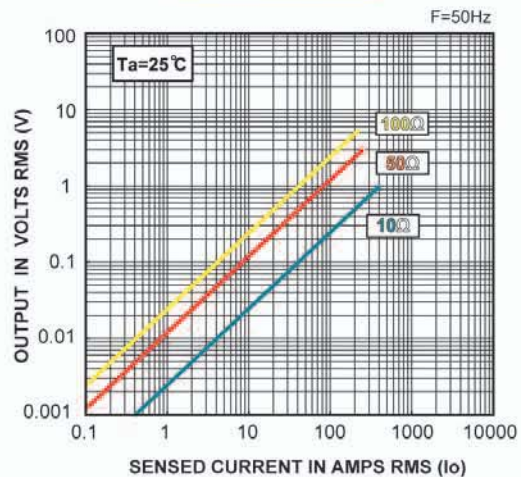

Output Voltage Data

Current Transformer

Output Voltage Data

CT1000

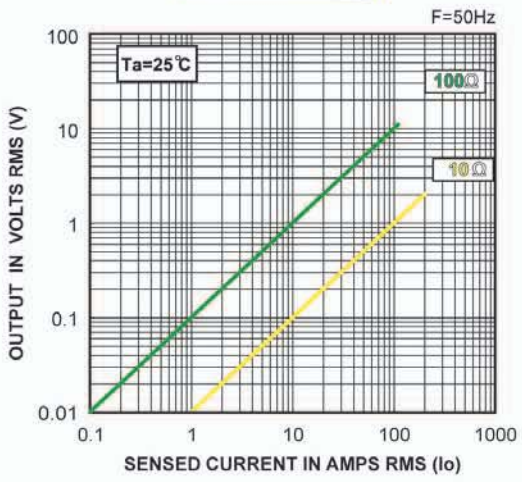

CT2000

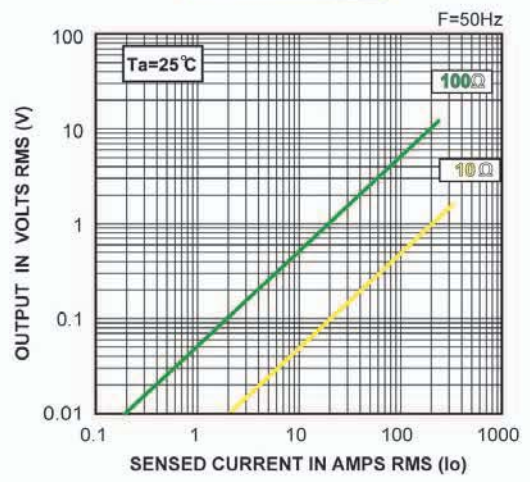

CT3000

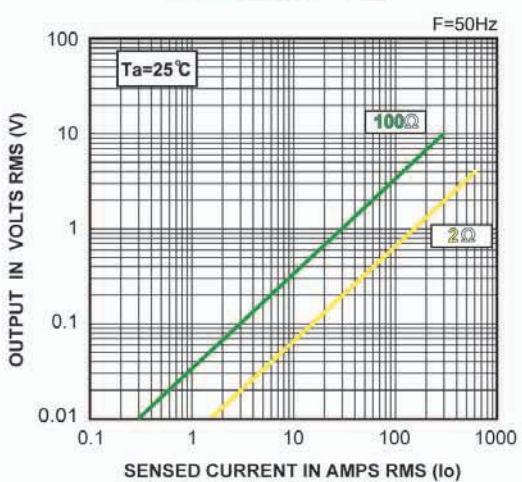

JCTP-80 / JCTH-80

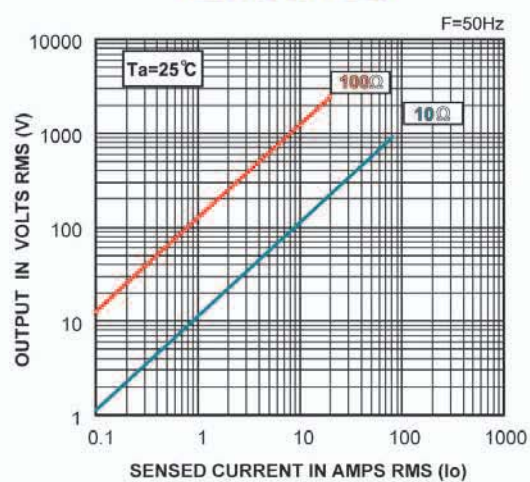

JH1000

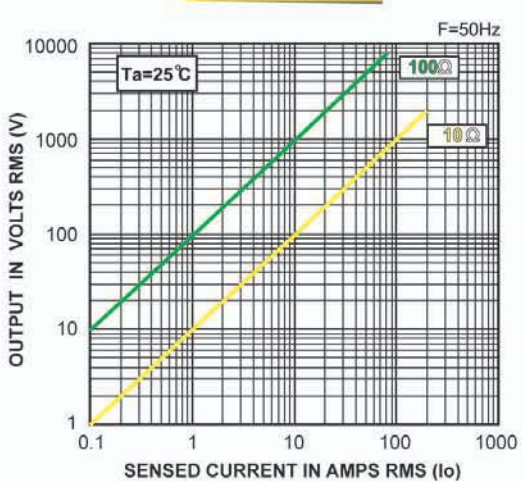

JG10

