

This sheet is made up of structure, specification and dimension.
 (本表係由產品之結構,規格,外形尺寸 所組成.)

1. Structure (結構)

Switch (開關)

Magnet (磁石)

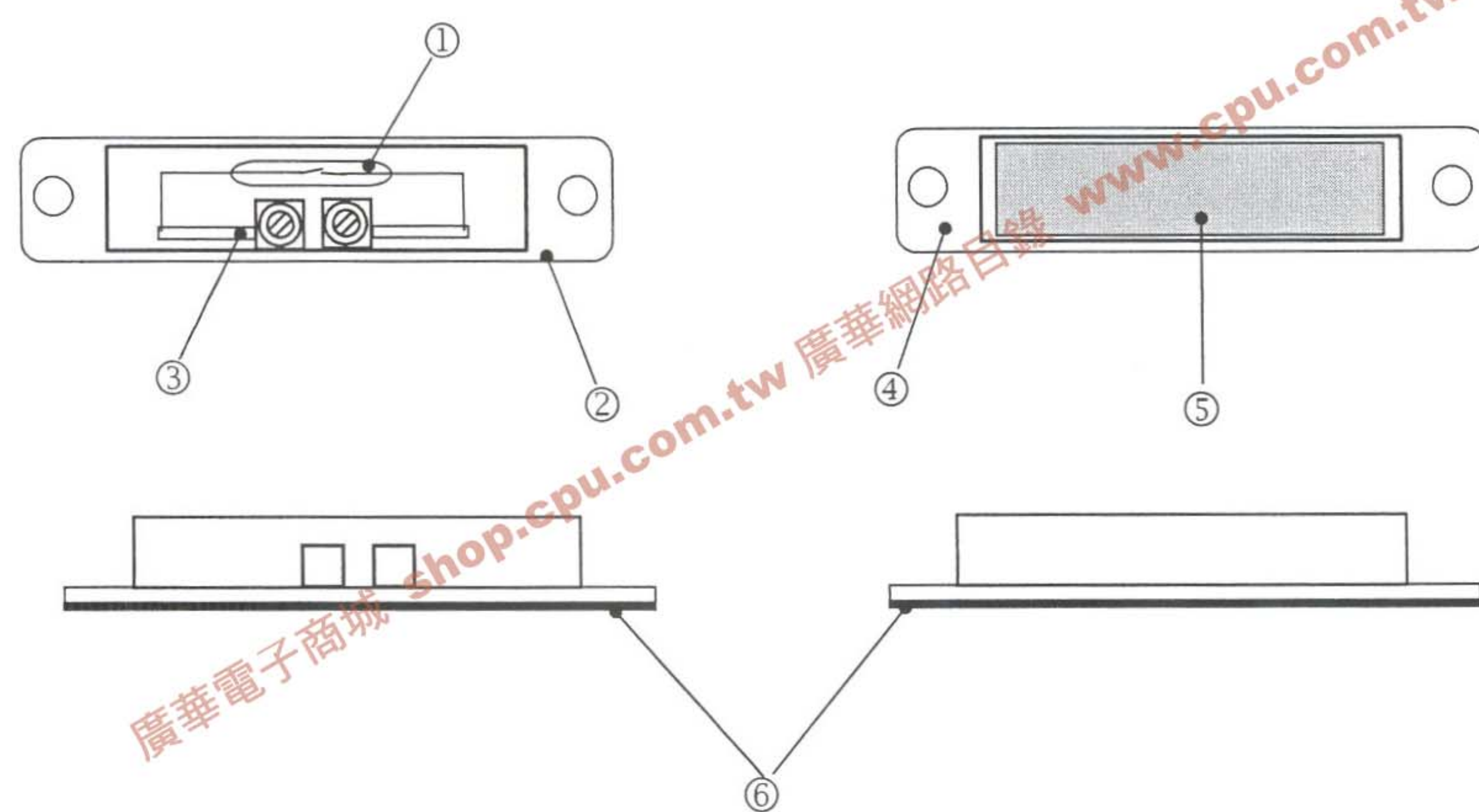

No.	Model (名稱)	Parts (項目)	Maker (製造元)
1	Reed Switch (磁簧管)	HYR1532	NIPPON ALEPH
2	Plastic Case (塑膠殼)	ABS Resin	CHI MEI IND. CO.
3	Screw Terminal (端子)	M2, Steel, Tin plated	SHI-HO Screw Co., (Nitto)
4	Plastic Case (塑膠殼)	ABS Resin	CHI MEI IND. CO.
5	Magnet (磁石)	Anisotropic ferrite	TA LIAN Magnet co.
6	Foam Tape (泡棉膠帶)	#4032	3M

2. Specification (規格)

Switch (開關)

2-1-1	Contact form 接點形式	: closed loop
2-1-2	Switching voltage (max.) 最大直流電壓	: 100v AC / DC
2-1-3	Switching current (max.) 最大直流電流	: 0.5A
2-1-4	Contact capacity (max.) 最大接點容量	: 10 VA
2-1-5	Initial contact resistance 接觸阻抗	: 0.2 Ohm max.
2-1-6	Carry current (max.) 承載電流	: 1 A
2-1-7	Breakdown voltage 接點耐電壓	: 200 VDC
2-1-8	Insulation resistance 絕緣阻抗	: 100 Mohm min.
2-1-9	Switch cycle 壽命	: 5x 10 ⁷ cycle at 30. V 0.1ADC

Magnet (磁石)

2-2-1	Material 材質	: Anisotropic ferrite
2-2-2	Residual flux density (Br) 殘留磁束密度	: 3300 -3600 Gauss
2-2-3	Maximun energy product (BH) max. 最大磁能積	: 2.5 -3.5 MG. Oe
2-2-4	Curie temperature (Tc) 居里溫度	: 450°C

Gap (距離)

2-3-1	Sense gap	: 20mm min.
-------	-----------	-------------

Physical characteristic (物理特性)

2-4-1	Temperature 使用周圍溫度	: -20°C— +60°C
2-4-2	Vibration 耐振動性	: 20 G (10— 55 Hz)
2-4-3	Shock 耐衝擊性	: 30 G (11 msec)
2-4-4	Heat shock 熱衝擊	: -25°C— +65°C (30min) (30min) 100 cycle
2-4-5	Package drop 落下容許高度	: Drop height 80 cm
2-4-6	Humidity 耐溼性	: 80°C 95% RH 72 hrs

3. Dimension (外形尺寸)

