

TRP-C06H

User's Manual

2-Port RS-232 to RS-422/485 Isolated Converter



Printed Feb.2007 Rev 1.1

Copyright

Copyright Notice: The information in this manual is subject to change without prior notice in order to improve reliability, design and function and does not represent a commitment on the part of the manufacturer. No part of this manual may be reproduced, copied, or transmitted in any form without the prior written permission of manufacturer. Acknowledgment Products mentioned in this manual are mentioned for identification purpose only. Products names appearing in this manual may or may not be registered trademarks or copyright of their respective companies.

1. Introduction

The TRP-C06H allows 2 RS-232 line signal to be bi-directionally converted to RS-422 or RS-485 standard and transmit data up to 1.2KM. Featuring automatic data format and baud rate detect function users just need to plug the unit and go without extra configuration efforts. TRP-C06H is equipped with 3000V DC of isolation and internal surge protection to protect the host computer and converter against high voltage spikes, as well as ground potential differences. The industry standard DIN rail and panel mounting design enable user a fast and professional installation.

1-1. Features

- Wide range input DC power supply.
- Automatic data format configuration.
- Auto direction flow control on RS-485.
- Auto baud rate switching from 300bps to 115.2Kbps.
- 3000V DC isolated protection.
- Surge protection on RS-422/485 data lines.
- Power/TX/RX mode LED indicator
- Support screw terminal and external DC adaptor.
- DIN rail or panel mounts support.

1-2. Specifications

- Power input voltage: DC +10V to +30V.
- Host connection: 2 standard D-Sub 9 pin female connectors.
- RS-232 signal: TXD, RXD, GND.
- RS-232 interface: Standard D-Sub 9 pin female connector.
- RS-422/485 interface: Industrial plug-in screw terminal.
- RS-485 signal: differential 2 half-duplex wires (D+, D-).
- RS-422 signal: differential 4 full-duplex wires. (TX+, RX+, TX-, RX-)
- Communication speed: form 300bps to 115.2Kbps auto detecting.
- RS-422/485 line protection: Against surge, short circuit, voltage peak.
- Distance: up to 4000ft (1200M).
- Isolation voltage: 3000V DC.
- Plug-in screw terminal wiring: Accepts AWG #12 ~ 30 wires.
- Signal LED: Power on, TXA, RXA, TXB, RXB.
- Power supply: Screw terminal, or external DC adapter.
- Power consumption: 1.3W
- Operating environment: 0 to 60°C .
- Storage temperature: -20 to 70°C .
- Humidity: 10-90% Non-condensing.
- Dimension: 151mm X 75mm X 26mm.
- Weight: 375g.

2. Hardware Description

The following information is to give users an understanding of how to connect the TRP-C06H with the serial device and a review of the functionality of the LED's.

2-1. TRP-C06H Panel layout

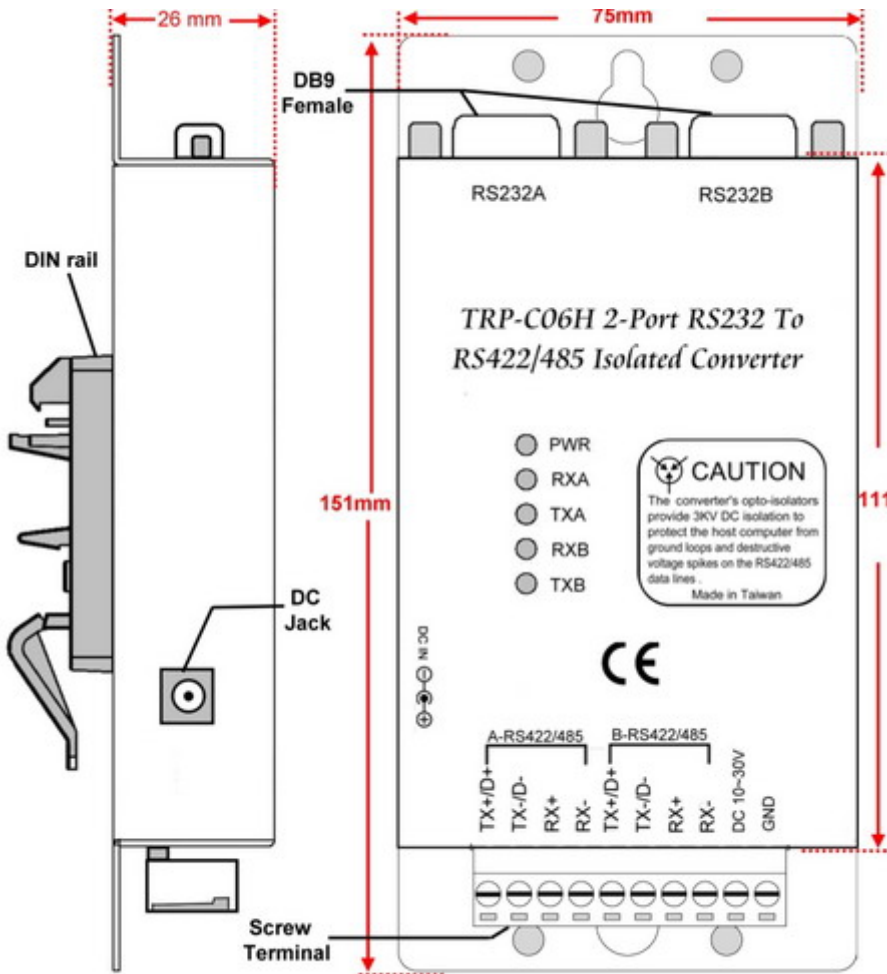

2-2. TRP-C06H Block Diagram

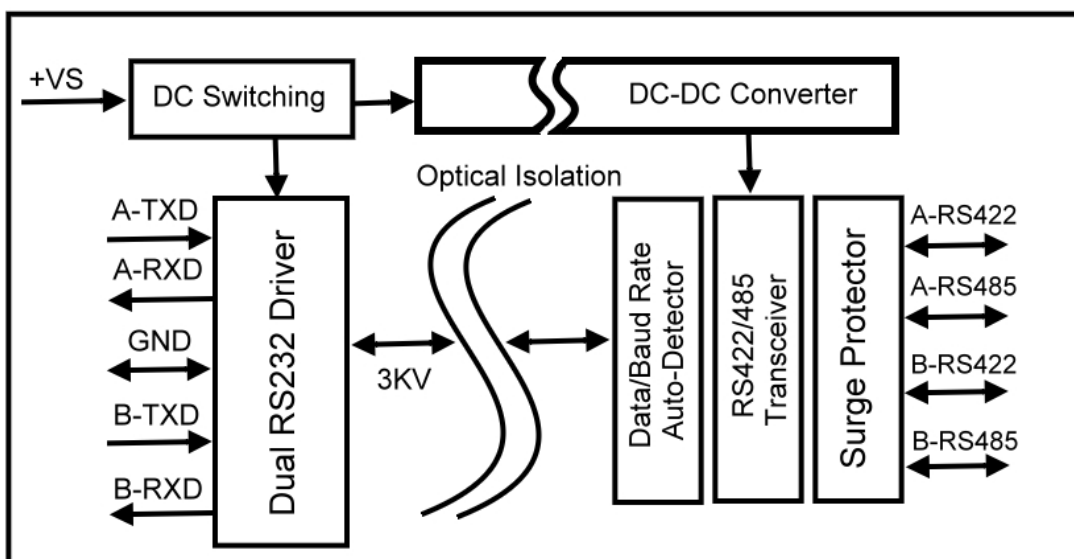

2-3. LED Indicator

PWR LED: System is ready.

RXA LED: RS-232-A Receiving.

TXA LED: RS-232-A Transmitting.

RXB LED: RS-232-B Receiving.

TXB LED: RS-232-B Transmitting.

3. Install TRP-C06H

3-1. TRP-C06H to Host Connection

The TRP-C06H has two DB-9 female and 4-wire RS-422 and 2-wire RS-485 connectors.

3-2. Power Connection

The TRP-C06H has a two pins terminal block and power jack. Power can be supplied from terminal block or external power adapter and supports wide input range from + 10~30V. When power is correctly supplied the PWR LED will lighting and indicates the system is up. It is highly recommended use the power jack specification 5.5*2.1*12mm if the power supply is from external DC plug.

Warning: User can only choose one of following 2 power sources.

1. External DC adapter.
2. Screw terminal DC input

Do not use both power input simultaneously.

3-3. RS-232 Female Pin Configuration (COMA and COMB)

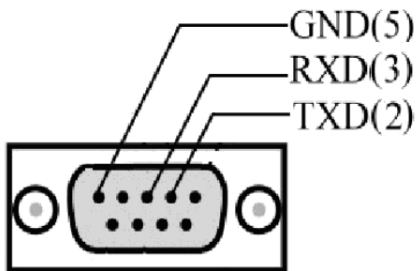

3-4. RS-232 wire connection



3-5. RS-422 wire connection

The TRP-C06H RS-422 mode supports 4 channels with full duplex operation for receive, transmit, and the data lines are in differential pairs. The wire connection is shown as

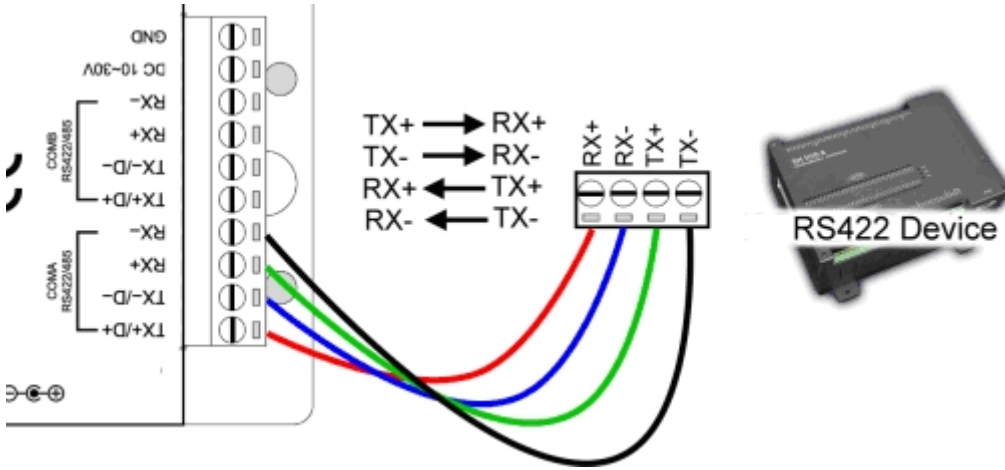

3-6. RS-485 wire connection

The TRP-C06H RS-485 mode supports transmit and receive channels by using 2-wire half-duplex operation. The wire connection is shown as

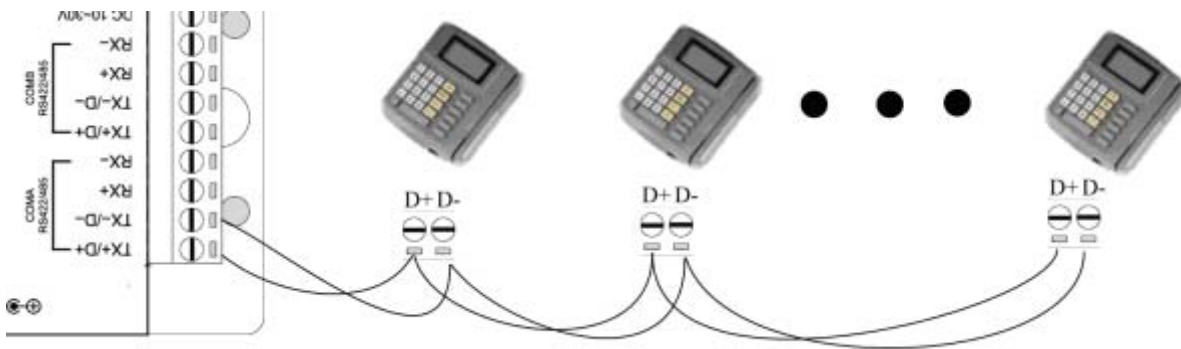

3-7. PC to RS-232 device by RS-422 wire connection.



4. How to test TRP-C06H

Trycom Technology Co.,Ltd offers demo and test utility, these utilities may help user to demo and test TRP-C06H fast and easily. User may find the utilities in Trycom support CD or download from Trycom web. [The testing utility includes](#)

RS-422 test utility

test422.exe for DOS

DEMO.exe for Windows

and RS-485 utility.

test485.exe for DOS

TRPCOM for Windows.

4-1. RS-422 loop back test

Refer to wire connection as below

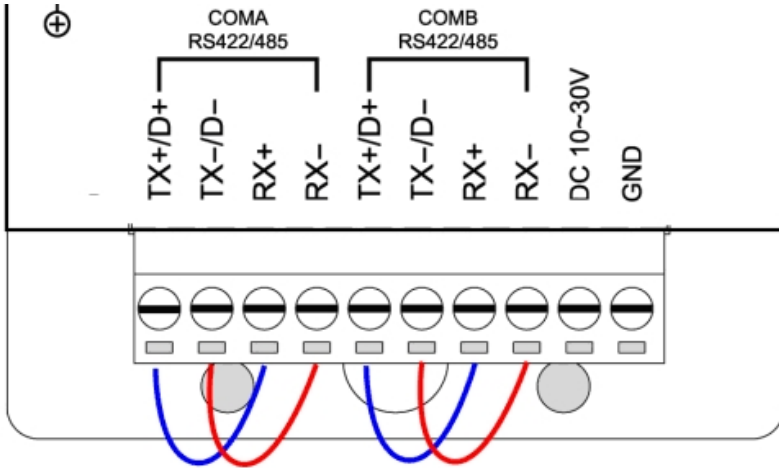

STEP1:Run the “DEMO.EXE” utility (See the Figure 1).

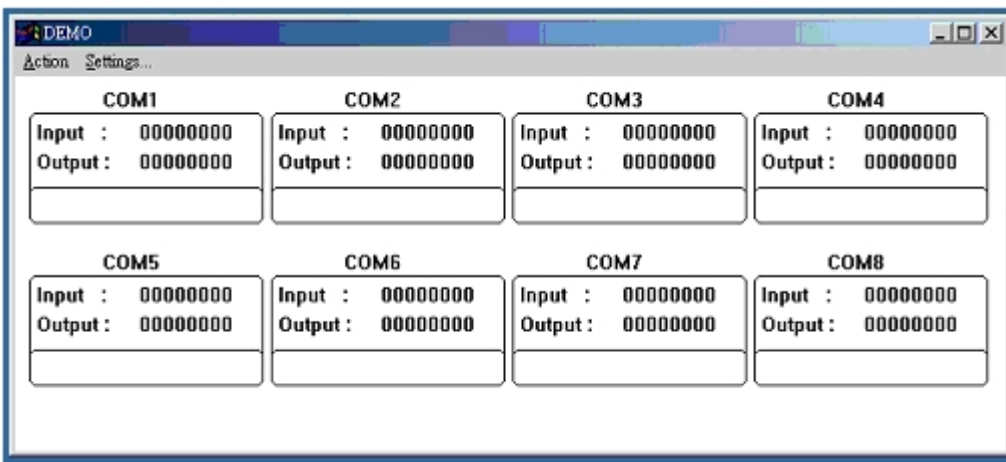

Fig.1

STEP2: Click the “Setting” to set the com port and baud rate (See the Figure 2); the demo setting screen will shown as Fig.2.



Fig.2

*Please note: “COM3” is an example of COM port number; the real COM number is assigned by your PC..

STEP3: Click the “OK” the utility will show the input and output status.

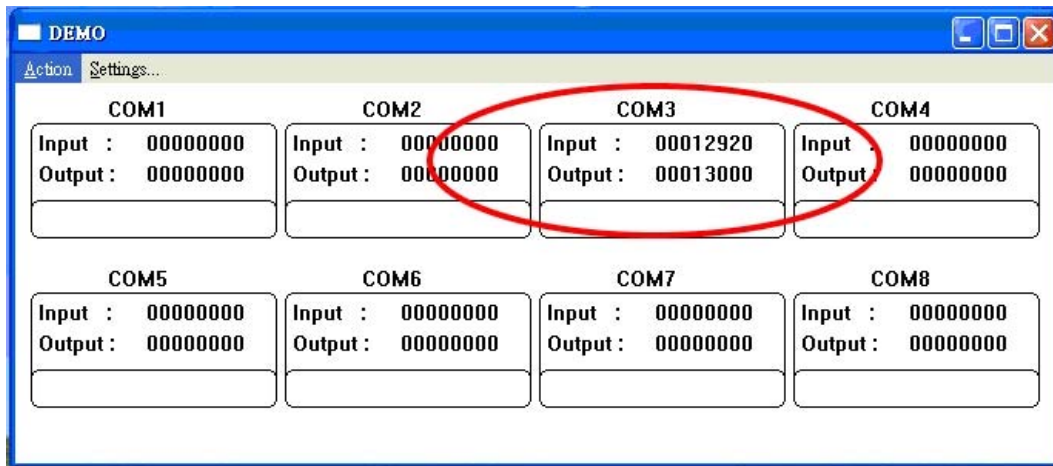

4-2. RS485 test

Refer to 3-6 for RS-485 wire connection. User may also directly link TRP-C06H to Trycom Remote IO modules, the wiring connection is as below.

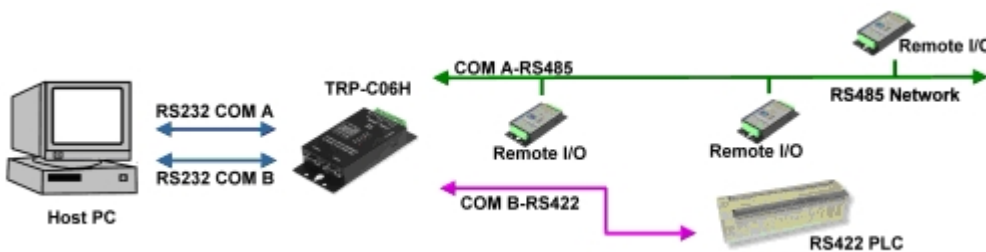

Step1. Install TRPCOM utility.

TRPCOM is a test utility which may help user to test TRP-C06H with RS485 device easily. User may find the utility in the TRP-C06H support disk. Double click “setup.exe”, the install wizard will guide you to complete the installation.

Step2. Configure COM port and baud rate, after configuration press “OK” to the next screen.

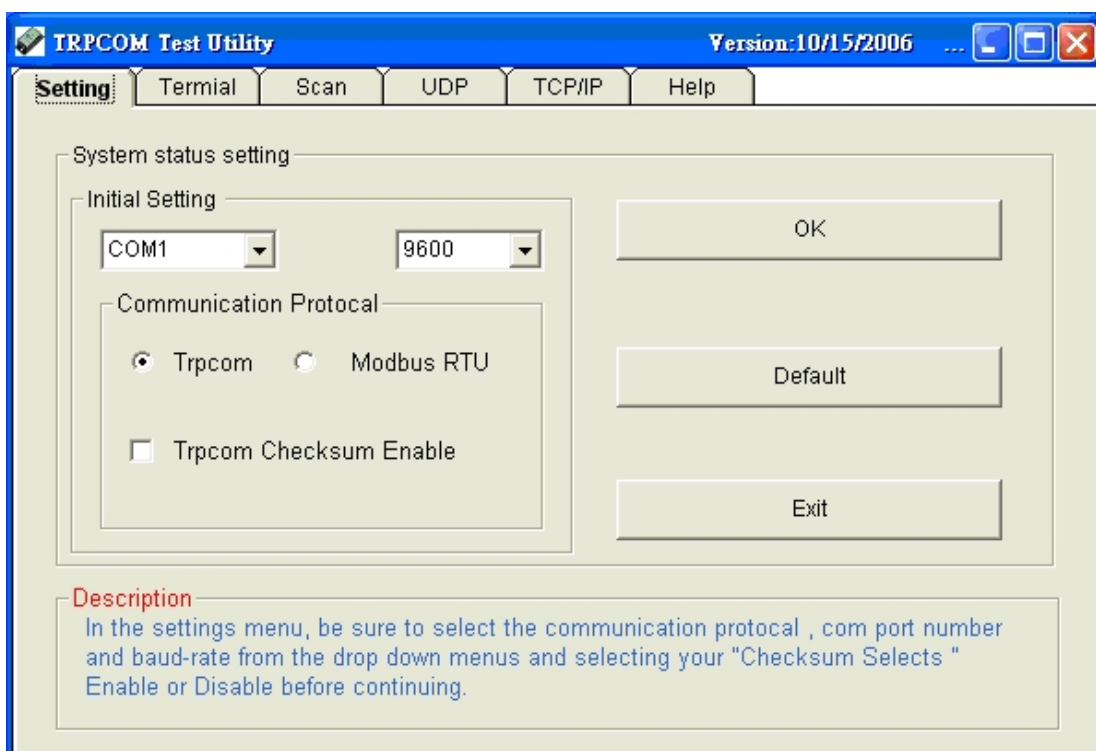

Step3.Send command "\$01M" and press "Send"

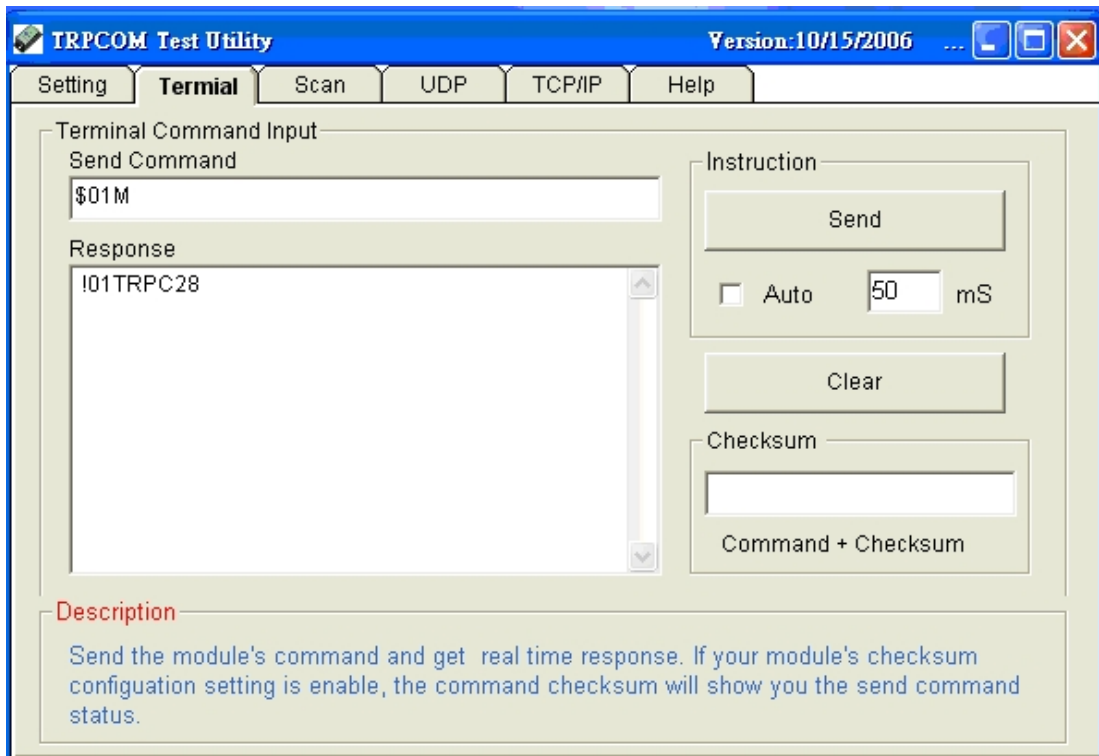

Step4. Data response received

Test complete.