



BLE V5.0 Beacon RS-232 Reader

Support “iBeacon™”, “Eddystone™”, “Altbeacon™”, Raw, TPMS, Sensors

Model: S2B5232RI

1. Package content:

<p>BLE Beacon RS-232 Reader</p>  <p>White Box Dimension: 11 x 6 x 5 (cm) Total Package Weight: 100 g</p> 	<p>Package Contents:</p> <ul style="list-style-type: none"> ● BLE RS-232 reader x 1 ● A4 User manual x 1 ● Mini USB Cable x 1 
---	---

2. Profile:

2.1 Top view:

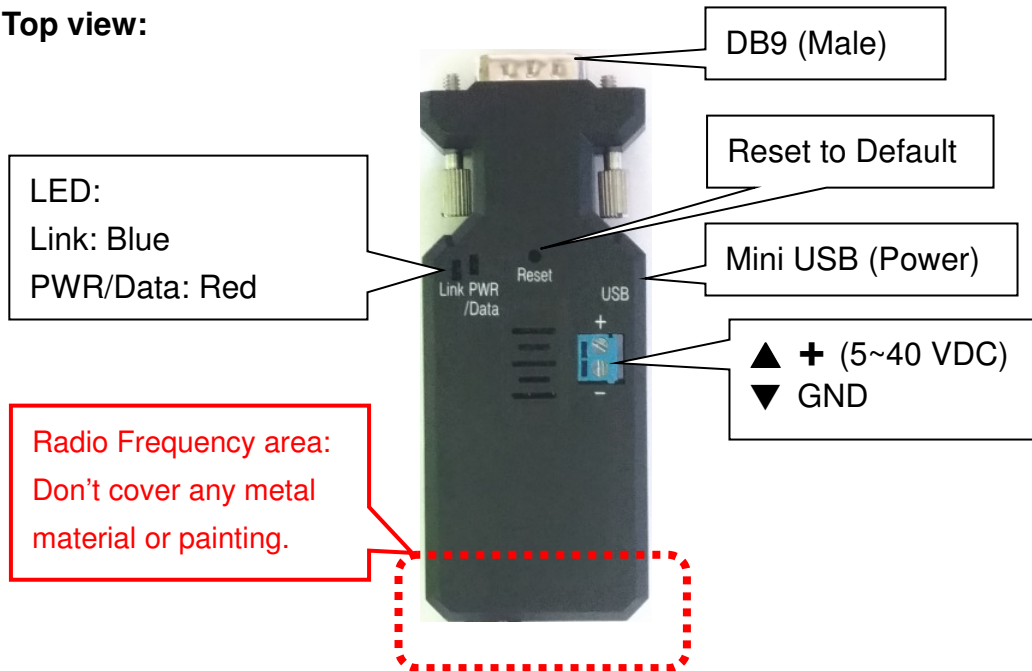

LED	Description
Blue	Flash when data received
Red	Solid when power on

2.2 DB9 connector: (Male)



2: RX 3: TX
5: GND 9: Vin

Pin	Signal	DTE Direction	DCE Direction	Description
1	N/A			
2	RxD	Output	Input	Transmitted data
3	TxD	Input	Output	Received data
4	N/A			
5	GND			Ground
6	N/A			
7	RTS			
8	CTS			
9	Vin			Power Input (5~27 VDC)

2.3 Rear Side:

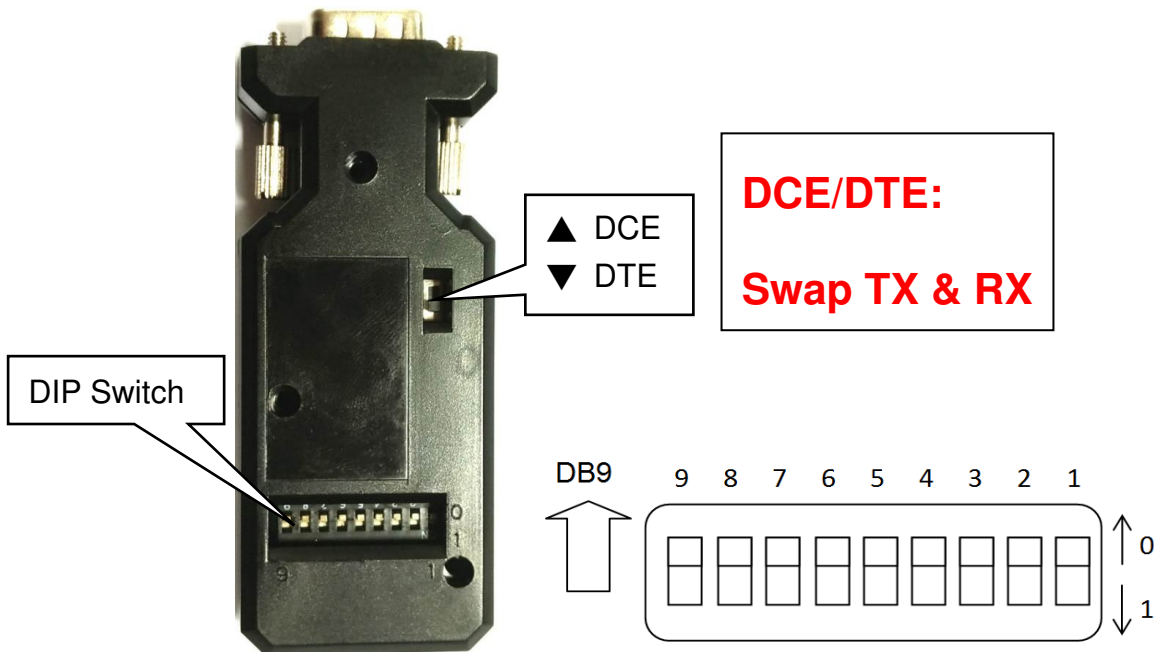

2.4 Default: All pin is "0", Baud rate 9,600 bps., 8 Data bits, None parity, 1 Stop bit.

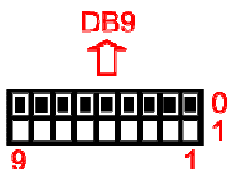

2.5 Baud rate option: DIP No. 8 is set to “1” (On): The baud rate is 115,200 bps, 8 Data bits, None parity, 1 Stop bit.

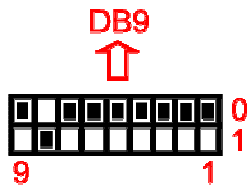

3. Packet Format:

3.1 Default: All DIP switch is “0”. The reader will filter “Uconnect™”, “iBeacon™”, “Eddystone™” or “Altbeacon™”.

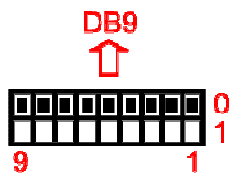

\$<msg type>,<reader id>,<tag type>,<tag id>,<battery>,<button>,<G-sensor>,<sensor>,<RSSI>#

Field	Description
\$	start of report
msg type	Type of message ex. 0: reserved, 1: Uconnect™ tag 2: iBeacon™, 3: Eddystone™, 4: Altbeacon™
reader id	6 bytes ID of reader in hex => 12 chars
tag type (*)	type of tag ex. 1: tag w/o g-sensor, 2: tag w/ g-sensor ..
tag id	6 bytes ID of tag in hex => 12 chars
tag batt (*)(**)	batt voltage of tag in 1/10 volt unit
tag button status (*)	button status ex. 0: released, 1: pushed
tag motion status (*)	motion status ex. 0: non-moving, 1: moving
Sensor (*)(***)	Various sensor data (11 bytes)
tag rssi	tag read rssi
#	end of report

Remark

1. (*): The message is “0” for iBeacon™, Eddystone™ and Altbeacon™ beacon.
2. (**): Eddystone™-TLM version 0 include the Tag battery information, 1/10V; The version is none “0” will display “0” in the “Tag batt” column.
3. (***): Tx Power for the iBeacon™, altBeacon™, Eddystone™-UID, Eddystone™-URL and Eddystone™-EID beacon

Example:

```
$1,00A05053849D,1,00A050172A2C,30,0,0,,-71#
$2,00A05053849D,0,58E72F0CEF88,0,0,0,0,-48#
$3,00A05053849D,0,772BB24ADC36,0,0,0,0,-48#
$4,00A05053849D,0,012AC345EB45,0,0,0,0,-49#
```

3.2 Raw BLE packet: The Bluetooth discovering broadcast will be filtered. All BLE beacon will be reported. DIP No. 1 is set to “1” (On) and “0” else

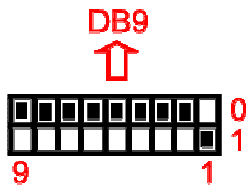

Prefix: “\$”

First column: RSSI value

Mac. ID: “00A05053849D”

Raw packet data is between “\$” and “CR” ”LF”

Suffix: CR LF

EX:

\$-78,00A05053849D,0201061BFF5900AABC0100A050172A2C1E00000000000000000000000000000000BB

\$-83,00A05053849D,1EFF06000109200073C68487B4DFB227B7546E97078954811C4EB1E40DC1DF

3.3 Add the “>” at the end of Raw BLE packet: DIP No. 2 is set to “1” (On) and “0” else

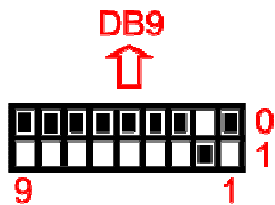

Prefix: “\$”

First column: RSSI value

Raw packet data is between “\$” and “>”

Suffix: “>”

EX: \$-85,02010605166E2A850A04160F18090F09425055434B205420383030423635>

3.4 Add the “>” and “CR” “LF”at the end of Raw BLE packet: DIP No. 2 is set to “1” (On) and “0” else

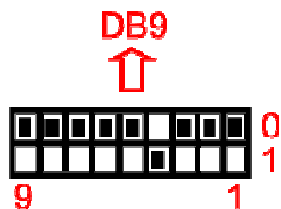

Prefix: “\$”

First column: RSSI value

Raw packet data is between “\$” and “>”

Suffix: “>” “CR” “LF”

3.5 Raw iBeacon® packet only: DIP No. 1 & 2 is set to “1” (On) and “0” else

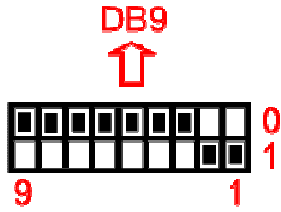

Prefix: “\$”

First column: RSSI value

Mac. ID: “00A05053849D”

Raw packet data is between “\$” and “CR” ”LF”

Suffix: “CR” ”LF”

EX: \$-85,00A05053849D,02010605166E2A850A04160F18090F09425055434B205420383030423635

3.6 Raw Eddystone™ packet only: DIP No. 1 & 2 is set to “1” (On) and “0” else

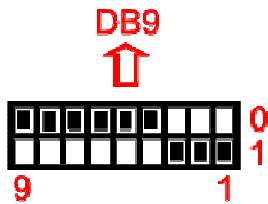

Prefix: “\$”

First column: RSSI value

Mac. ID: “00A05053849D”

Raw packet data is between “\$” and “CR” ”LF”

Suffix: “CR” ”LF”

EX: \$-85,00A05053849D,02010605166E2A850A04160F18090F09425055434B205420383030423635

3.7 TPMS packet: DIP No. 3 is set to “1” (On) and “0” else

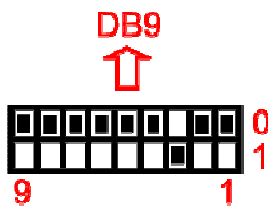

Raw data, EX: 66F35AC800

3.8 GPS Tracker & TPMS: DIP No. 1 & 3 is set to “1” (On) and “0” else, Add “AT\$SNDTXT=” with TPMS packet as the section 3.6

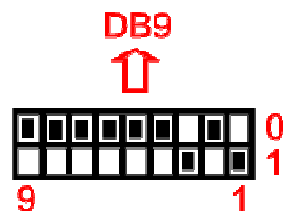

EX: AT\$SNDTXT=66F35AC800

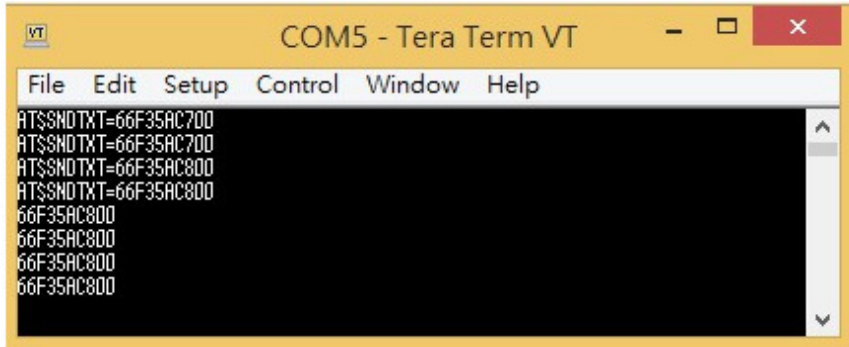

3.9 GPS Tracker & iBeacon™ tag In/Out: DIP No. 2 & 3 is set to “1” (On) and “0” else

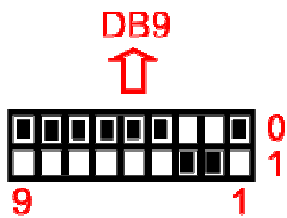

3.9.1 When a new iBeacon™ is detected, flag=1, major, minor, power and RSSI

EX: 1;23A01AF0232A45189C0E323FB773F5EF00010002C523

1 = new beacon

UUID = 23A01AF0232A45189C0E323FB773F5EF

major = 0001

minor = 0002

measured power = C5

RSSI = 0x23

3.9.2 When the iBeacon™ left the device (life time ~30sec.), flag=0

EX: 0;23A01AF0232A45189C0E323FB773F5EF00010002

0 = lost beacon

UUID = 23A01AF0232A45189C0E323FB773F5EF

major = 0001

minor = 0002

3.9.3 Output format: 0x02 [data from §3.8.1 & §3.8.2] 0x0D 0x0A 0x03

EX: 0x02 1;23A01AF0232A45189C0E323FB773F5EF00010002C523 CR LF 0x03

3.10 TPMS APP for ID setting: DIP No. 6 is set to “1” (On) and “0” else

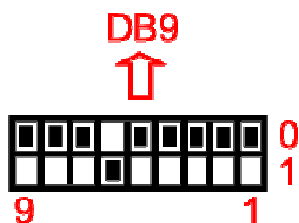

3.11 TPMS APP for ID setting: DIP No. 1 & 6 is set to “1” (On) and “0” else, Add “AT\$SNDTXT=” with TPMS packet as the section 3.10

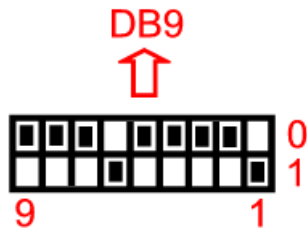

3.12 Customized beacon tag: Kontakt, MineW

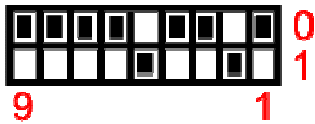

4. Power supply:

4.1 Voltage: 5~40 VDC, **Don't exceed the limit.**

4.2 There're 3 ways to power the adapter: Mini USB, Terminal Block and pin9 of DB9, please choose one. **Don't power the adapter by more than one source.**

4.3 The mini USB cable is inside the standard package.